

SET UP FOR SPORT-MECHANIC REPAIR STAND

FEATURES

FIGURE 1

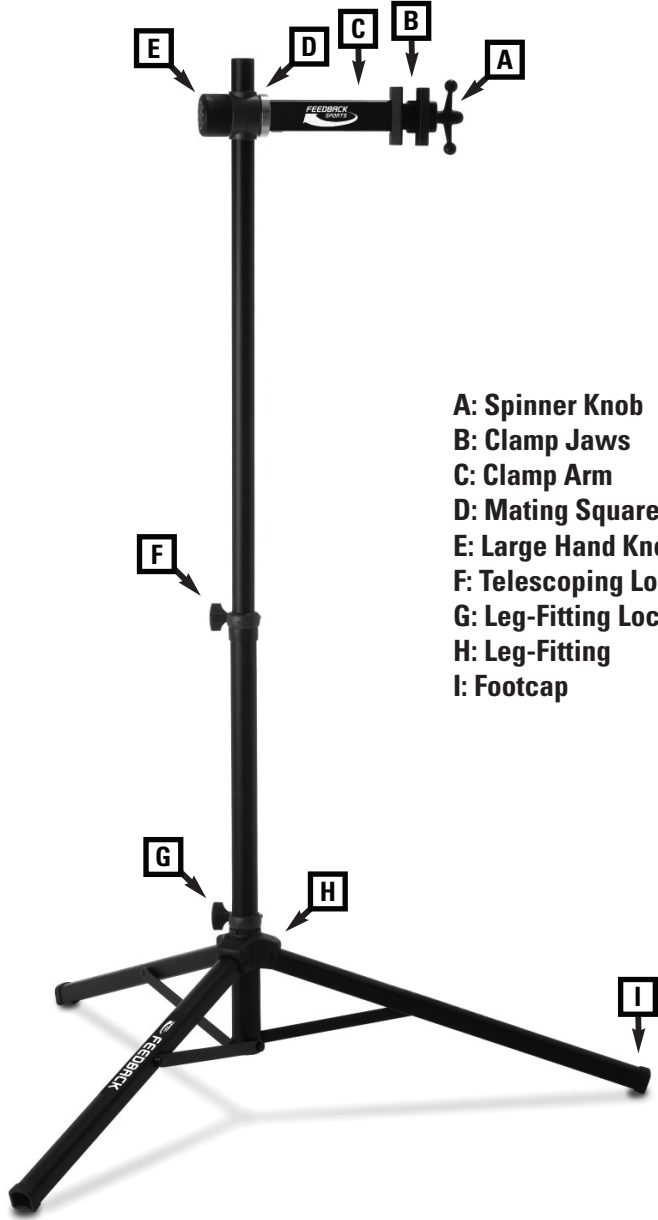

- A: Spinner Knob
- B: Clamp Jaws
- C: Clamp Arm
- D: Mating Square Recessed Socket
- E: Large Hand Knob
- F: Telescoping Lock Knob
- G: Leg-Fitting Lock Knob
- H: Leg-Fitting
- I: Footcap

SET UP_UNFOLD THE STAND

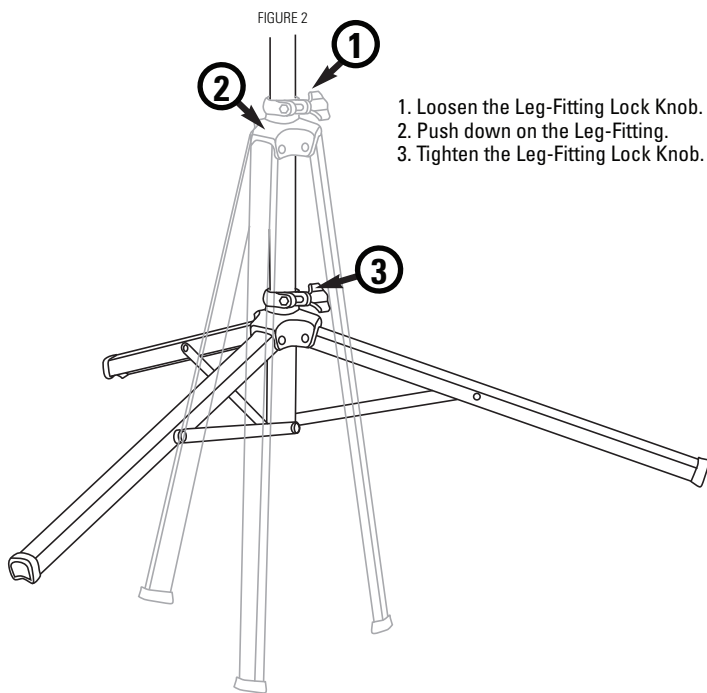

1. Loosen the Leg-Fitting Lock Knob.
2. Push down on the Leg-Fitting.
3. Tighten the Leg-Fitting Lock Knob.

SET UP_UNFOLD THE CLAMP HEAD

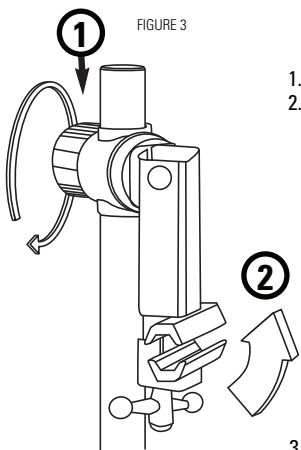

1. Loosen the Large Hand Knob (D) on the Clamp Arm (C) until it stops.
2. Pull and lift the Clamp Arm into a horizontal position.

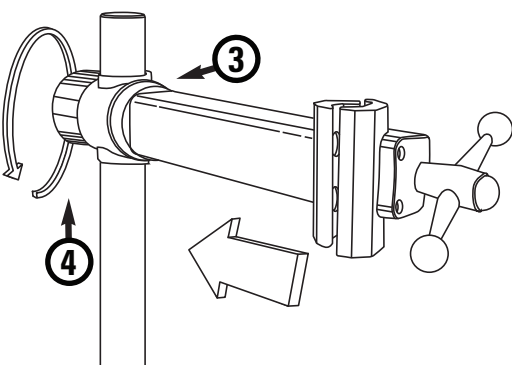

3. Insert Clamp Arm into mating square recessed socket.
4. Tighten the Large Hand Knob

BICYCLE & THE STAND

PLACING BICYCLE IN THE STAND

1. Rotating the Spinner Knob counter-clockwise until Jaws are opened enough to accept the width of the seatpost.

FIGURE A

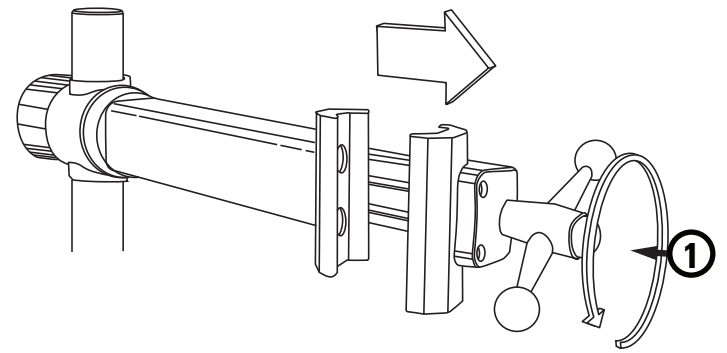

2. Lift and place seatpost into the clamp against the inner Jaw.
3. Rotate the Spinner Knob clockwise until appropriate clamping force is reached (enough to keep the bike from slipping during work).

FIGURE B

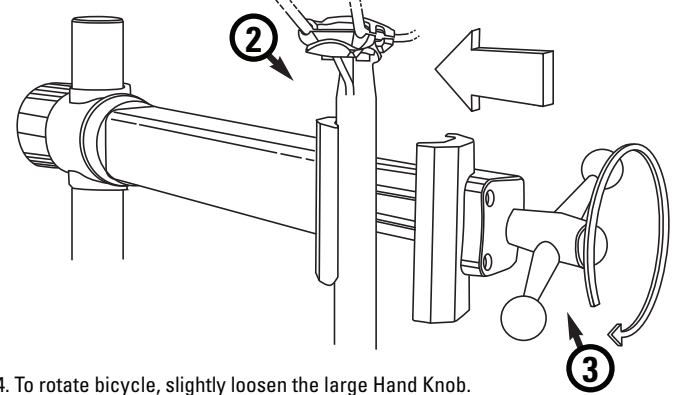

4. To rotate bicycle, slightly loosen the large Hand Knob.
5. Rotate bike to desired position and re-tighten. (will not harm the clutch mechanism to rotate under load)

FIGURE C

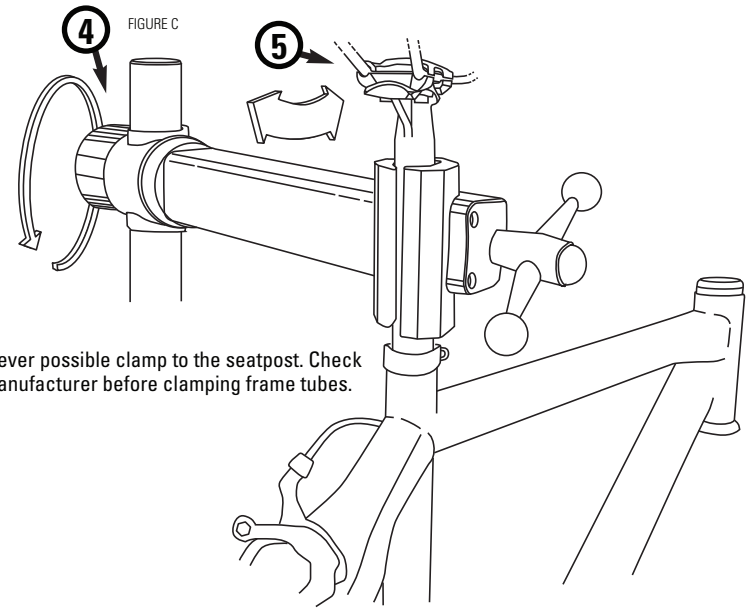

NOTE: Whenever possible clamp to the seatpost. Check with bicycle manufacturer before clamping frame tubes.

REMOVING BICYCLE FROM THE STAND

1. Securely hold bike & rotate the Spinner Knob counter-clockwise until Jaws are loose enough to release the tube.
2. Lift bicycle out of Jaws.

FIGURE D

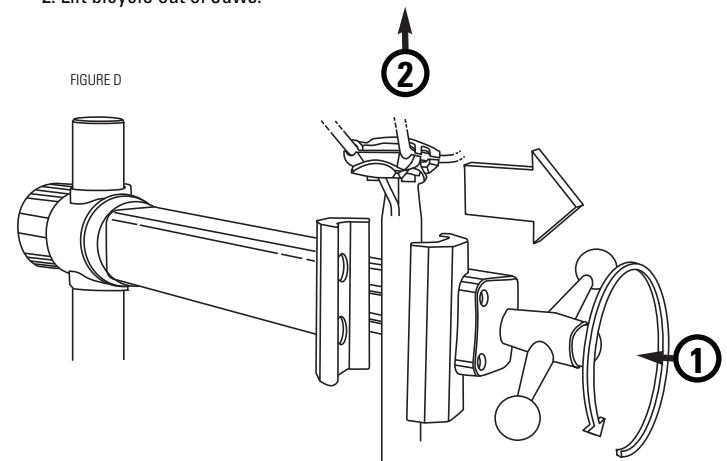

MAINTENANCE TIPS

> If excess clamp jaw friction is present, the threaded rod for the Vise lock clamp jaw needs to be lubricated with a standard chain lube. To accomplish this, just unscrew the clamp jaw until the outer jaw assembly is free. Pull the assembly out and lightly lube the threaded rod and reinstall.

> Maximum grip on the bicycle is achieved when the jaws are free from any oil or dirt. Small amounts of any oil, including hand oil, can cause the jaws to under perform. When needed, clean jaws with alcohol or detergent a damp cloth.