

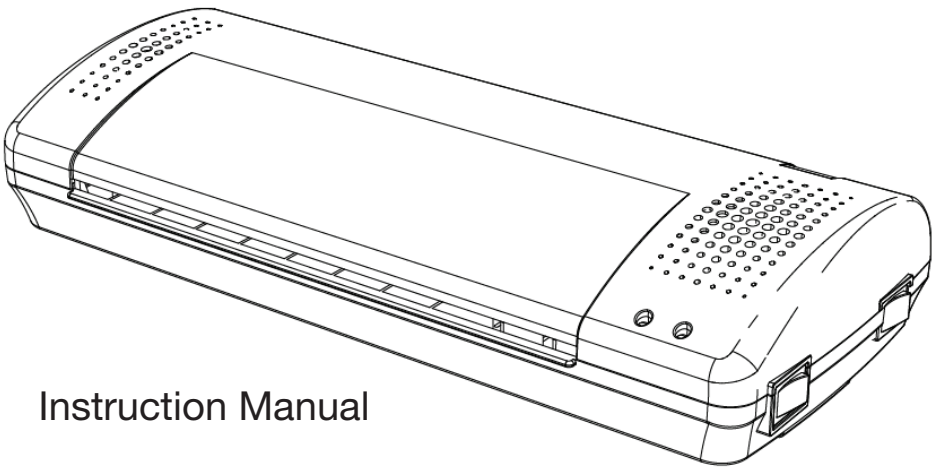

Swingline[®]

Swingline[®] Inspire[™] Plus Laminator



Instruction Manual

To register this product go to www.swingline.com 



Product Diagram

Front

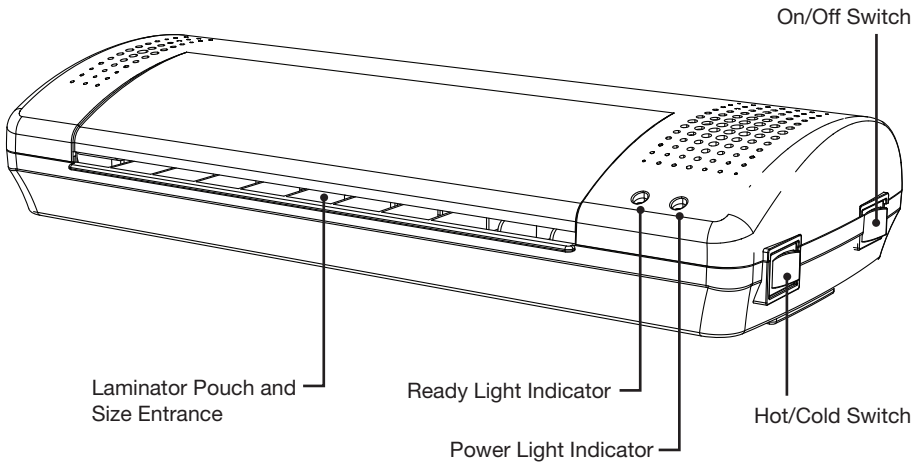

Back

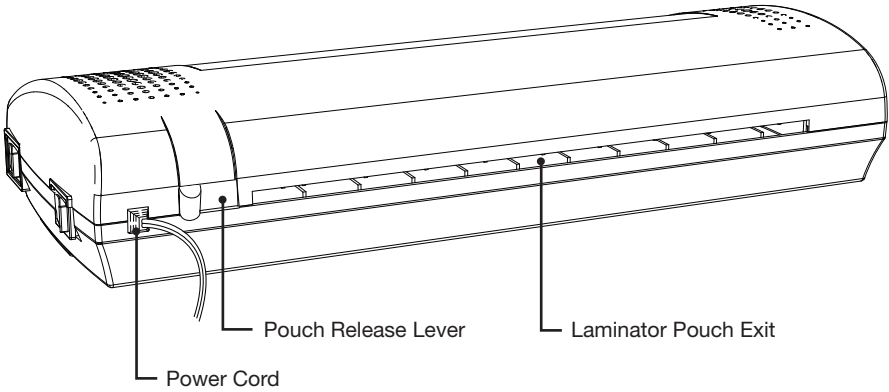

Safety Instructions



YOUR SAFETY AS WELL AS THE SAFETY OF OTHERS IS IMPORTANT TO ACCO BRANDS. IN THIS INSTRUCTION MANUAL AND ON THE PRODUCT ARE IMPORTANT SAFETY MESSAGES. READ THESE MESSAGES CAREFULLY.



THE SAFETY ALERT SYMBOL PRECEDES EACH SAFETY MESSAGE IN THIS INSTRUCTION MANUAL.

THIS SYMBOL INDICATES A POTENTIAL PERSONAL SAFETY HAZARD THAT COULD HURT YOU OR OTHERS, AS WELL AS CAUSE PRODUCT DAMAGE OR PROPERTY DAMAGE.

Important Safeguards



WARNING: FOR YOUR PROTECTION, DO NOT CONNECT THE POUCH LAMINATOR TO ELECTRICAL POWER UNTIL YOU READ THESE INSTRUCTIONS COMPLETELY. KEEP THESE INSTRUCTIONS IN A CONVENIENT LOCATION FOR FUTURE REFERENCE. TO GUARD AGAINST INJURY, THE FOLLOWING BASIC SAFETY PRECAUTIONS MUST BE OBSERVED IN THE SET-UP AND USE OF THIS PRODUCT.



WARNING: TO AVOID ELECTRICAL SHOCK OR OTHER INJURY, THE FOLLOWING SAFETY PRECAUTIONS MUST BE OBSERVED.

Electrical Safeguards

- The unit must be connected to a supply voltage corresponding to the electrical rating shown on the unit.
- Unplug the unit before moving it, or when it is not in use for an extended period of time.
- Do not operate with a damaged supply cord or plug. Do not alter the attachment plug. The plug is configured for the appropriate electrical supply.
- Do not overload electrical outlets beyond their capacity. Fire or electrical shock could result.
- The unit is intended for indoor use only.
- Never push objects through the housing slots. Do not spill liquid of any kind on this product.
- Close supervision is required when this product is used near children.

General Safeguards

- Use the unit only for its intended purpose of laminating documents.
- Do not place anything in the throat opening of the laminator other than pouches/documents.
- Place unit on a secure, stable work area to prevent the unit from falling and possibly causing personal injury and damage to the unit.
- Follow all warnings and instructions.
- The socket outlet shall be installed near the equipment and shall be easily accessible.
- Do not attempt single side lamination, this will destroy the laminator.
- Do not block the vent slots, this will cause the laminator to overheat.

Introduction

Thank you for purchasing this Swingline® Inspire™ Plus Laminator. Please take the time to study these instructions to ensure the best results out of your machine.

For best lamination results and performance, use only Swingline® pouches.

Your new laminator may emit a slight odor during the initial operation. It is normal and will diminish after a few hours of operation.

Operation

1. Insert plug into electrical outlet.
2. Switch the unit to On (I) with the switch located on the side of the unit (Fig 1). The power light will turn on. Note: Use Cold setting for cold adhesive, or pressure sensitive, pouches.
3. Position the document to be laminated into a Swingline® laminating pouch, so that the document is aligned to the sealed edge and the right and left borders are equal (Fig 2).
4. When the ready light turns on, insert the pouch and its contents straight into the machine, leading with the sealed edge (Fig 3).
5. The laminated item will exit from the rear of the machine. Once the laminated pouch has stopped moving, it should be removed quickly from the back of the unit. This will help prevent unwanted jams and wrinkling.
6. When finished, switch the unit to Off (O) using the power switch located on the side of the unit (Fig 1).

Note: If pouch does not appear at back, turn off the machine, slide and hold the release lever, and remove the pouch by pulling towards you (Fig 4).

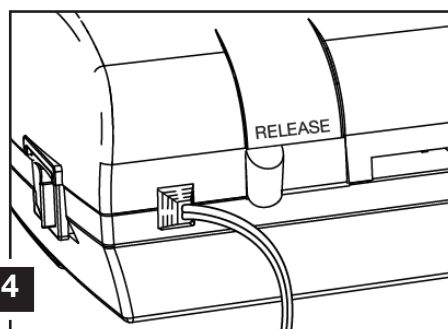
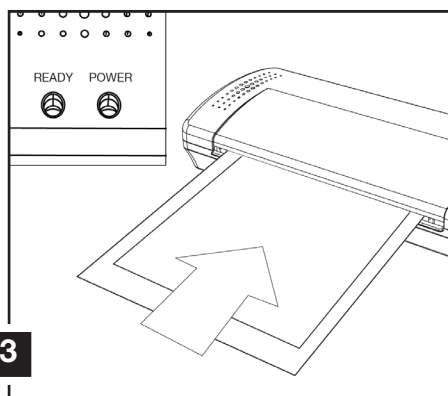
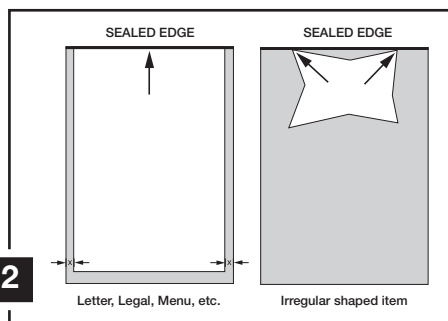
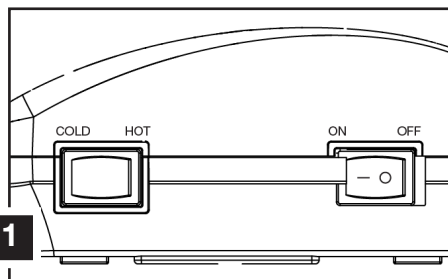

Technical Specifications

	Swingline® Inspire™ Plus Laminator
Electrical	120VAC 60Hz 2.2A 265W(Watt)
Machine Dimensions	2.56 x 5.91 x 13.78 inches (65 x 150 x 350 mm)
Machine Weight	2.2 lbs. (1.0 kg)
Maximum Pouch Width	9.2 inch (241.3 mm)
Maximum Pouch Thickness	3 mil and 5 mil up to legal size
Maximum Through-put Thickness	0.5 mm
Warm-Up Time	Approximately 4 minutes
Speed	9.8 inches (250 mm) per minute

Service

Do not attempt to service or repair the pouch laminator yourself. Unplug the unit and contact an authorized Swingline® service representative for any required repairs.

Cleaning



WARNING: UNPLUG THIS PRODUCT BEFORE CLEANING THE EXTERIOR. WIPE EXTERIOR ONLY WITH A DAMP CLOTH AND DO NOT USE DETERGENTS OR SOLVENTS.

Regularly feed a cleaning card or sheet of paper through the laminator to clean the rollers.

Laminating Tips

- DO NOT LAMINATE AN EMPTY POUCH.
- Never insert the loose end of the pouch first into the machine. This could cause the machine to jam. Always insert the sealed edge first.
- Before laminating important or unique documents, always run a test pouch through the laminator using a similar type document.
- Do not attempt to do single sided lamination. This will destroy the laminator.
- As soon as hot lamination is completed, remove the lamination from the rear of the machine and place on a cool flat surface for cooling to prevent the pouch from curling.
- Do not block the vent slots, this will cause the laminator to overheat.
- Do not cut pouches prior to lamination.
- Do not use with a carrier.

Limited 90 Day Warranty

ACCO Brands USA LLC, Four Corporate Drive, Lake Zurich, Illinois 60047 (in Canada, ACCO Brands Canada Inc., 5 Precidio Court, Brampton, ON L6S-6B7; and in Mexico, ACCO Mexicana, S.A. de C.V. Av. Circuito Industrial Norte #6 Parque Industrial Lerma 52000, Lerma Edo. de México) (each, respectively, "ACCO Brands") warrants to the original purchaser that this ACCO Brands product is free from defects in workmanship and material under normal use and service for a period of 90 days after purchase.

ACCO Brands' obligation under this warranty is limited to replacement or repair, at ACCO Brands' option, of any warranted part found defective by ACCO Brands without charge for material or labor. Any replacement, at ACCO Brands' option, may be the same product or a substantially similar product that may contain remanufactured or refurbished parts. This warranty shall be void in the following circumstances:

- (i) if the product has been misused,
- (ii) if the product has been damaged by negligence or accident, or
- (iii) if the product has been altered by anyone other than ACCO Brands or ACCO Brands' authorized agents.

For warranty execution, please call 1-800-541-0094 in the USA/1-800-268-3447 in Canada/1-800-759-6825 in Mexico or go to www.swingline.com.

TO THE EXTENT ALLOWED BY APPLICABLE LAW, THIS WARRANTY IS IN LIEU OF ALL OTHER EXPRESSED WARRANTIES. REPRESENTATIONS OR PROMISES INCONSISTENT WITH OR IN ADDITION TO THIS WARRANTY ARE UNAUTHORIZED AND SHALL NOT BE BINDING ON ACCO BRANDS. TO THE EXTENT PERMITTED BY APPLICABLE LAWS, ANY IMPLIED WARRANTIES (IF APPLICABLE) ARE LIMITED IN DURATION TO THE DURATION OF THIS WARRANTY. SOME STATES AND JURISDICTIONS DO NOT ALLOW LIMITATIONS ON HOW LONG AN IMPLIED WARRANTY LASTS, SO THE ABOVE LIMITATION MAY NOT APPLY TO YOU. TO THE EXTENT PERMITTED BY APPLICABLE LAW, IN NO EVENT SHALL ACCO BRANDS BE LIABLE FOR ANY SPECIAL, INCIDENTAL, PUNITIVE, EXEMPLARY, CONSEQUENTIAL OR SIMILAR DAMAGES, WHETHER OR NOT FORSEEABLE. SOME STATES AND JURISDICTIONS DO NOT ALLOW THE EXCLUSION OR LIMITATION OF SPECIAL, INCIDENTAL, PUNITIVE, EXEMPLARY, CONSEQUENTIAL, OR SIMILAR DAMAGES, SO THE ABOVE EXCLUSION OR LIMITATION MAY NOT APPLY TO YOU.

FOR CONSUMERS WHO HAVE THE BENEFIT OF CONSUMER PROTECTION LAWS OR REGULATIONS IN THEIR JURISDICTION OF PURCHASE OR, IF DIFFERENT, IN THEIR JURISDICTION OF RESIDENCE, THE BENEFITS CONFERRED BY THIS WARRANTY ARE IN ADDITION TO ALL RIGHTS AND REMEDIES CONVEYED BY SUCH CONSUMER PROTECTION LAWS AND REGULATIONS.

To the extent permitted by law, this warranty is not transferable and will automatically terminate if the original product purchaser sells or otherwise disposes of the product.

This warranty gives you specific legal rights. Other rights, which vary from jurisdiction to jurisdiction, may exist. In addition some jurisdictions do not allow (i) the exclusion of certain warranties, (ii) limitations on how long an implied warranty lasts and/or (iii) the exclusion or limitation of certain types of costs and/or damages, so the above limitations may not apply.

FCC CLASS B NOTICE

This device complies with Part 15 of the FCC Rules. Operation is subject to the following two conditions:

- This device may not cause harmful interference.
- This device must accept any interference received, including interference that may cause undesired operation.

Note: This equipment has been tested and found to comply with the limits for a Class B digital device, pursuant to part 15 of the FCC Rules. These limits are designed to provide reasonable protection against harmful interference in a residential installation. This equipment generates, uses and can radiate radio frequency energy and, if not installed and used in accordance with the instructions, may cause harmful interference to radio communications. However, there is no guarantee that interference will not occur in a particular installation. If this equipment does cause harmful interference to radio or television reception, which can be determined by turning the equipment off and on, the user is encouraged to try to if this equipment does cause harmful interference to radio or television reception, which can be determined by turning the equipment off and on, the user is encouraged to try to correct the interference by one or more of the following measures:

Reorient or relocate the receiving antenna.

Increase the separation between the equipment and receiver.

Connect the equipment into an outlet on a circuit different from that to which the receiver is connected.

Consult the dealer or an experienced radio/TV technician for help.

CANADA CLASS B NOTICE

This Class B digital apparatus complies with Canadian ICES-003

MODIFICATIONS

Any modifications made to this device may void the authority granted to the user by the FCC and/or by Industry Canada to operate this equipment.

Swingline



swingline.com/register
ACCO Brands (Returns Center)
101 Bolton Ave 9E
Booneville, MS 38829 USA
Tel: 800-541-0094

Made to Swingline
Standards in China.

©2014 ACCO Brands. All rights reserved.
ACCO® and Swingline® are registered trademarks
and Inspire™ is a trademark of ACCO Brands.

07157P002_0714